



A140

Innovation By Design



General Information

Kaori's new global standard 3-in-1 premium performance heat exchanger solutions is engineered for Refrigerated compressed air dryers perfectly dehumidify compressed air. The most compact designed combined with excellent heat transfer is listed as one of the smallest refrigerated air dryer heat exchanger in the world.

Reliable, no leaks, truly corrosion resistance, energy savings, simple solution, and greater cost benefits are of vital importance that Kaori hear from you. Hence, we devoting significant research and development efforts driven by customer demand and launched The A140 refrigerated air dryer heat exchanger.

The non-demister heat exchanger combines precooler, evaporator and separator plus zero loss drain, patent design avoid the clogging problem and ensure the reliability you trust from Kaori.

All stainless steel plates and separator with copper brazed plate heat exchanger has rigorous mechanical strength, ensures high corrosion resistance to protect critical pneumatic operations which result in the life of the dryer.

Utilizing innovative technological approach eliminates the cost of separator, worry-free leakage detection and installation complexity help customers increased productivity and process uptime.

Compact structure and the optimized heat exchanger reduces the amount of refrigerant, air dryer size, lower total cost of consuming electrical power, save money, space and low operation costs.

Connector Size

Air Side



2" Female thread

Refr. Side

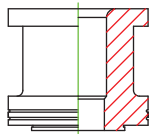

Ø19.3mm Soldering

Capacity

kW	55 ~ 75	kW
Air Flow Rate	7.0 ~ 14.0	Nm ³ /min
	420 ~ 840	Nm ³ /hr

Specifications

Quality Materials

Connections	Stainless Steel
Plates, Separator	Stainless Steel
Brazing Material	99.9% Pure Copper

Technical Data

Max. working temperature	200 °C	
Max. working pressure	Air Side	16 bar
	Refr. Side	30 bar
Min. test pressure	Air Side	23 bar
	Refr. Side	43 bar

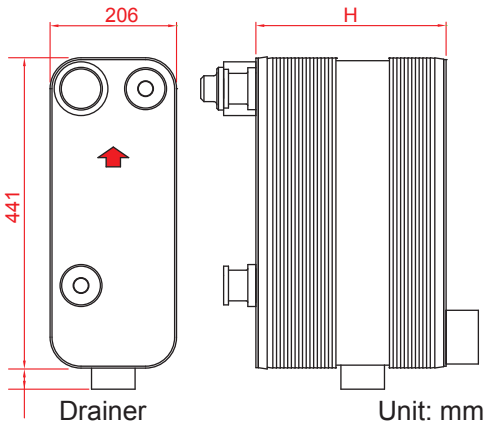

The Benefits Add Up

- No Demister, No Clog
- 3-in-1 Premium Design, Simply Integrates Pre-Cooler, Evaporator and Separator
- Steady Pressure Drop
- Stainless Steel, High Durability, Superior Reliability
- High Efficiency, Result in Compact Dryer Design

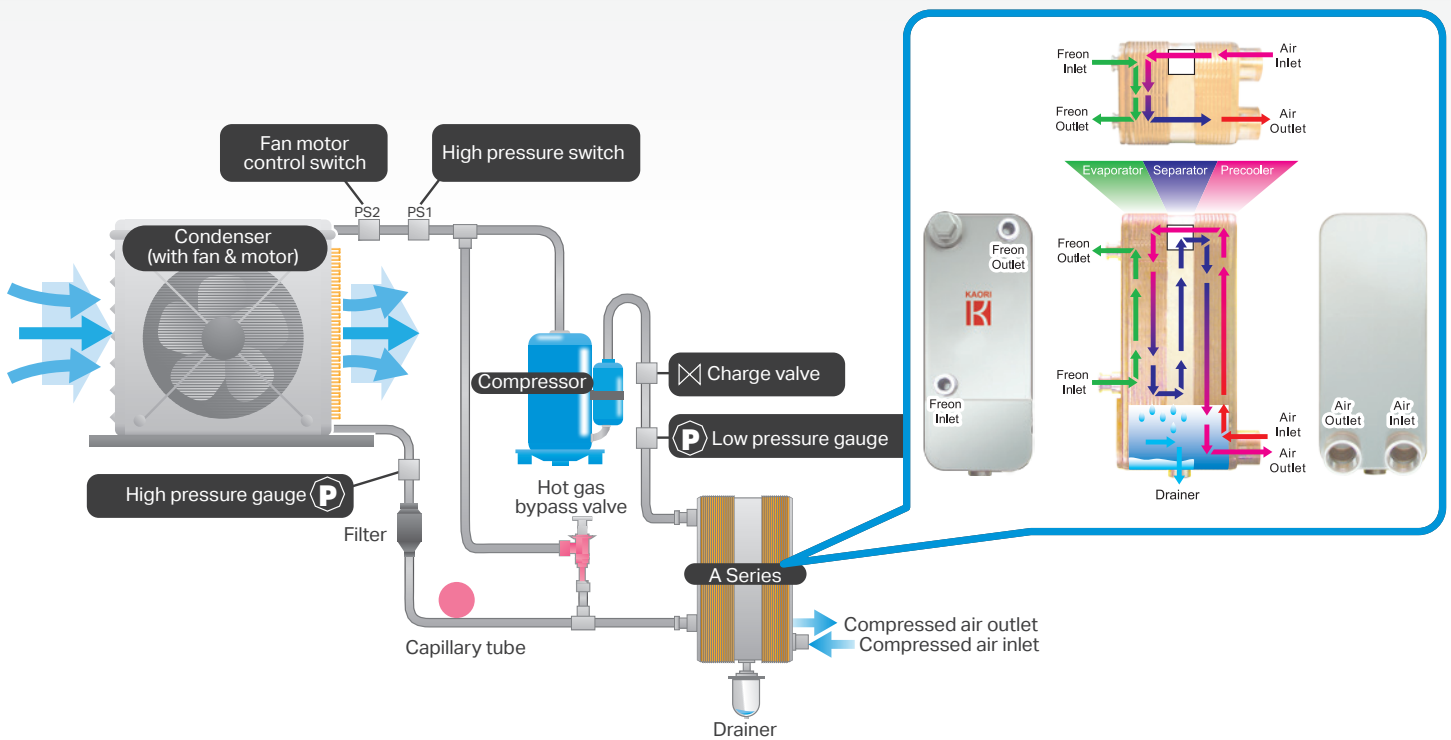
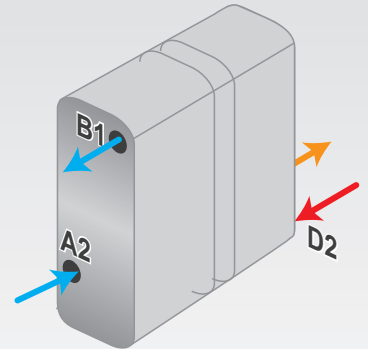

Model	Air Side Flow Rate			Weight (Kg)	Thickness H(mm)
	Nm ³ /min	Nm ³ /hr	sCFM		
A140-24-36	11.00	660.0	390.07	30.7	227.9
A140-32-44	14.00	840.0	496.45	36.2	284.7

* Design data: 8 bar (abs), $t_{dew} = 3^{\circ}\text{C}$ (37.4 $^{\circ}\text{F}$), $dp = 20 \text{ kPa}$ $t_{in-out} = 8-10 \text{ k}$

* The above information is for reference only; the data will be different under various working conditions and specifications.

This information is intended to serve as a reference and is not subject to guarantee. Precise inquiries are necessary for accurate information regarding performance specifications and suitability under specific working conditions.

Responsibility rests on purchasers to decide whether products are appropriate for use before purchasing. Kaori is not liable for corrosion of products and/or other equipment from use of products. Kaori reserves the right to make changes to this information without prior notice.

