



PROSİSTEK
Profesyonel Sistem Teknolojileri



K095



General Information

To fulfill the thermal exchanging, K095 uses longer flow channel on each plate, and it well suits the conditions which has minor gap in inlet&outlet temperature, such as air cooling and heat recovery. K095 is also comtatable with application featured in small flow volume but huge temperature gap, such as heat pump and regioal heating system.

Industries

HVAC,Heat pump,Chiller,Oil cooler,Processing cooling,heating

Connection (up to)



Male Thread
PT 1-1/4"



Female Thread
PT 1"



Solder
1-3/8"

Applications

Evaporator/Condenser, De-superheater/Subcooler, Economizer,
Oil Cooler,Pre-cooler/Pre-heater

Max. Heat Transfer Capacity

35.16 KW

Specifications

Standard Materials

Cover Plates	Stainless Steel
Connections	Stainless Steel
Plates	Stainless Steel
Braze Material	Copper

Standard Data

Max. working temperature °C	200
Max. working pressure (bar)	30
Min. test pressure (bar)	43
Max. flow rate (LPM)	260
Max. number of plates (N)	120
Plate Heat Transfer Area (M ²)	0.0475 m ²
Thickness (mm) - H	11.0+2.38*N
Weight (kg)	2.83+0.204*N
(without connection)	
N: Number of Plates	

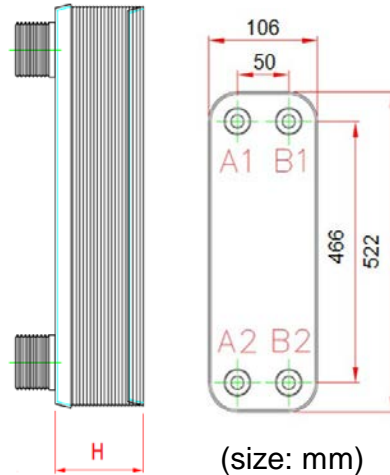

Material disclaimer

This information is intended to serve as a reference and is not subject to guarantee. Precise inquiries are necessary for accurate information regarding performance specifications and suitability under specific working conditions. Responsibility rests on purchasers to decide whether products are appropriate for use before purchasing. Kaori is not liable for corrosion of products and/or other equipment from use of products. Kaori reserves the right to make changes to this information without prior notice. Third party approvals and certifications are available upon request.

Kaori Heat Treatment Co., Ltd. Innovation • Quality • Responsibility • Honor

Prosistek Mühendislik Endüstri San. Ve Tic. Ltd. Şti.

Hacı Halil Mah. 1207. Sok. No:1/5
Gebze/Kocaeli - Turkey

Tel : +90 553 957 45 96

info@prosistek.com.tr
www.prosistek.com.tr