

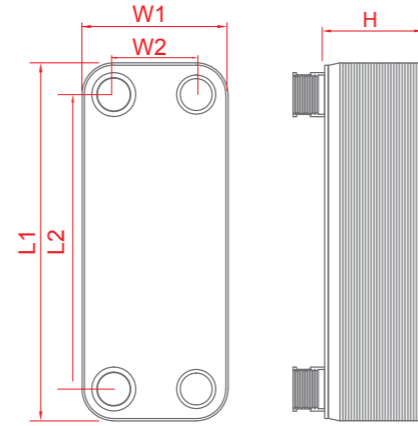

R Series Specifications

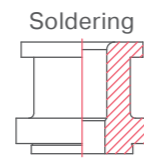
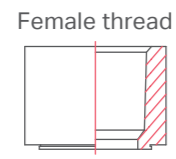
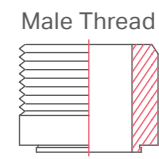

Standard Materials												
Connections	Stainless Steel											
Plates	Stainless Steel											
Brazing Material	99.9% Pure Copper											
Model	R020	R040	R050	R095	R200	R215	R021	R041	R051	R096	R201	R216
Max. Working Pressure (bar)	30/ 30						45/ 30					
Min. Test Pressure (bar)	43/43						65/ 43					
Max. Working Temperature (°C)	200											

Technical Data								
Model	L1 (mm)	L2 (mm)	W1 (mm)	W2 (mm)	H Thickness (mm)	Weight*(kg) (Without Connection)	Heat Transfer Area/ plate (m ²)	Total Heat Transfer Area (m ²)
R020	191	154	77	40	7.0+1.15*N	0.62+0.042*N	0.0111	(N-2)*0.0111
R040	311	278	73	40	7.5+1.30*N	0.63+0.070*N	0.0195	(N-2)*0.0195
R050	306	250	106	50	9.3+1.80*N	1.20+0.089*N	0.0255	(N-2)*0.0255
R095	522	466	106	50	10.0+1.80*N	2.75+0.160*N	0.0475	(N-2)*0.0475
R200	613	519	186	92	14.0+2.05*N	6.94+0.385*N	0.0945	(N-2)*0.0945
R215	529	449	247	167	14.0+1.85*N	7.89+0.430*N	0.1103	(N-2)*0.1103

Model	L1 (mm)	L2 (mm)	W1 (mm)	W2 (mm)	H Thickness (mm)	Weight*(kg) (Without Connection)	Heat Transfer Area/ plate (m ²)	Total Heat Transfer Area (m ²)
R021	191	154	77	40	7.0+1.15*N	0.62+0.042*N	0.0111	(N-2)*0.0111
R041	311	278	73	40	7.5+1.30*N	0.63+0.070*N	0.0195	(N-2)*0.0195
R051	306	250	106	50	11.3+1.80*N	2.22+0.089*N	0.0255	(N-2)*0.0255
R096	522	466	106	50	10.0+1.80*N	2.83+0.160*N	0.0475	(N-2)*0.0475
R201	613	519	186	92	17.0+2.05*N	11.83+0.385*N	0.0945	(N-2)*0.0945
R216	529	449	247	167	17.0+1.85*N	13.51+0.430*N	0.1103	(N-2)*0.1103

This information is intended to serve as a reference and is not subject to guarantee. Precise inquiries are necessary for accurate information regarding performance specifications and suitability under specific working conditions. Responsibility rests on purchasers to decide whether products are appropriate for use before purchasing. Kaori is not liable for corrosion of products and/or other equipment from use of products. Kaori reserves the right to make changes to this information without prior notice.

KAORI Brazed Plate Heat Exchanger R Series Micro Channel

High Heat Transfer Performance



Next Generation Heat Exchanger for R290 & Low GWP Refrigerants

With the continuous advancement of global trends on new refrigerant technology, KAORI has successfully implemented innovative design to decrease refrigerant charge while increasing energy efficiency with next generation R Series Brazed Plate Heat Exchangers (BPHEs).

Through leadership in development of new generation heat exchangers in the industry, the R series demonstrate effective solution for future renewable energy system that is equipped with Hydrocarbon refrigerants such as Propane (R290), new low GWP refrigerants such as R32, and HFO blend refrigerants such as R-448A, R-449A, R-450A, R-452A, R-452B, R-458A, R-513A, R1234yf, R1234ze(E) etc....

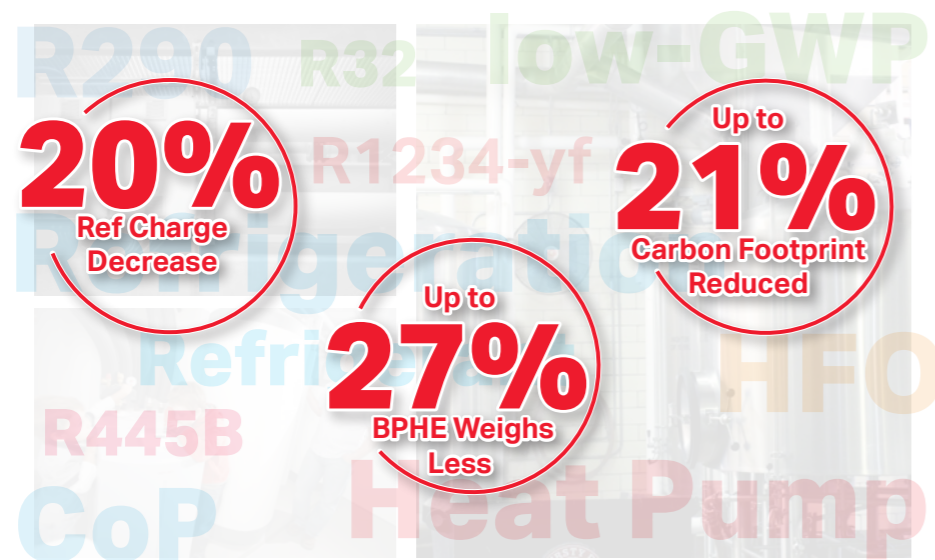

Features

Micro Channel Design

The Micro channel plate is designed by reducing the internal volume that helps decreasing the amount of refrigerant charge along with reduced overall weight. This offers significant cost savings, and results in increased profits.

Meet Optimal Thermal Performance

Thermal optimization of R series Heat Exchanger also offers higher efficiency that improves the performance of heating and cooling systems.

Good Handling of Icing Conditions

While the R series acting as both an Evaporator and Condenser in Heat Pump system, the plate geometrical characteristic play a vital role during defrost. By implementing the variety of geometries and degree of complexity plates prevent the ice formation during the defrost cycle.

Robust Solution

The brazing technique becomes very important for high stability. KAORI enhances the brazing joints to increase higher pressure and fatigue resistance, this enables KAORI to offer the very robust solution to Heating & Cooling industry and grow reputation for its standards and achievements.

Achieve Proper Refrigerant Mass Distribution

New flow distribution technology is embedded in the R series to provide a good distribution quality for two phase refrigerant flows, delivering the best system performance.

With the help of innovative and highly efficient new plate design, the R Series offers advantages in lowering refrigerant charge, high heat transfer and good handling of icing conditions. These lead to lower operation costs, achieve highest efficiency, offer more affordable heating and cooling solution for all future renewable energy systems, such as new generation heat pump, refrigeration and air conditioning systems that use low GWP Refrigerants and Natural fluids.

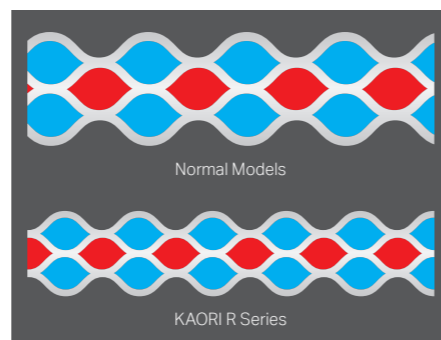

R Series for Heat Pump/ Chiller Application

Low GWP refrigerants has come to light due to legislation and energy efficiency standards. By continuously investing in research and development, KAORI proposed R series, a family of Micro Channel solutions which reduce refrigerant charge and provide outstanding efficiency in performance, helping engineers to speed up the development of next generation Heat pump and Chiller systems.

Major applications of R Series Brazed Plate Heat Exchangers include evaporators for air conditioning chillers, condensers and economizers for heat pump systems.

The technology also gives the Heating and Cooling systems' manufacturers the opportunity to extend new application such as district heating, district cooling, space heating, process heating and process cooling. Achieving cost-effective as well as environmentally responsible solution.

With its robust core technology, Kaori is continuing to develop new generation heat exchangers to further support low-GWP alternatives transition, and provide benefit to every sector in commercial and industrial heating and cooling market as easy as possible.

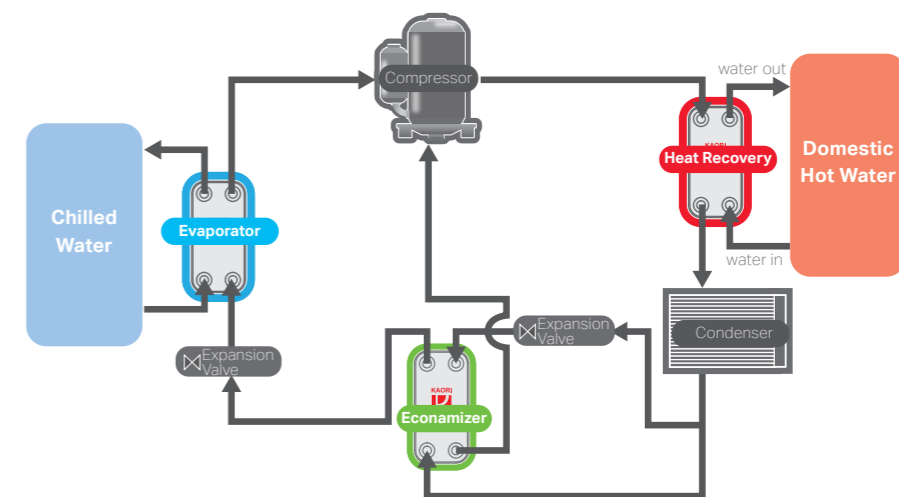

R Series for Commercial Refrigeration Application

Commercial refrigeration market has been adopting alternative Low-GWP natural refrigerants like R290 (Propane), CO₂ and HFO refrigerants for next generation refrigeration systems.

Especially using natural refrigerants in the water-cooled condensing display case units (water loop system), this not only brings low GWP benefit but also offers compactness in size. They require only small refrigerant charge thanks to efficient KAORI R Series micro channel Brazed Plate Heat Exchanger that is specially designed to minimize system charging.

By implementing the R Series Brazed Plate Heat Exchanger, the heat rejection of the display cases in the supermarket can be transferred to outdoor or applied efficiently to other applications where heat is needed. It also helps to improve indoor air quality indirectly and continuously reduce the energy consumption in supermarket, thus lowering costs and further contributing to protect the environment.

